

www.UltrasonicMetallurgy.com

Ultrasonic vibrations in metallurgy with MMM Technology

Degassing of Al alloys

Grain refinement of Al alloys

by M. Prokic

MP Interconsulting
Marais 36,
2400 Le Locle, Switzerland
www.UltrasonicsWorldGroup.com

Phone: +41-32-9314045
Fax: +41-32-9314079
www.mpi-ultrasonics.com
mpi@mpi-ultrasonics.com

Patent

European Patent Application (related to MMM technology): EP 1 238 715 A1
Multifrequency ultrasonic structural actuator
Applicant: **Prokic Miodrag**, MP Interconsulting, 5.03.2001 – 11.09.2002

Proposals for your factory: Cavitation in Metallurgy

Degassing

Principle:

Supplying acoustic energy to a melt in order to stimulate Sonocrystallisation:

- (i) A great number of small cavities developed inside the liquid
- (ii) Diffusion of hydrogen from the melt to developed bubbles
- (iii) Large bubbles coagulate and float to a surface of a liquid metal

Besides degassing, the development of cavitation promotes significant undercooling and formation of numerous solidification nucleuses.

Grain refinement exerts a positive influence on several properties of cast aluminum, namely: porosity, shrinkage distribution, intermetallic distribution. It improves significantly mechanical properties.

Refinement
of
 α -Al

Ultrasound above the threshold of acoustic cavitation can be introduced into a molten metal promoting:

Degassing of liquid metals using high intensity ultrasonic activity.

Grain refinement, Si eutectic and intermetallic modification.

MPI Dedicated Software Control

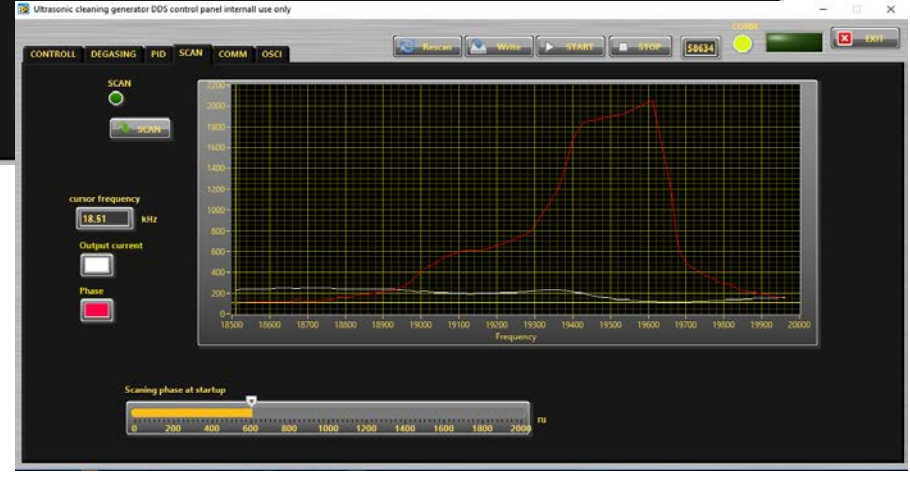
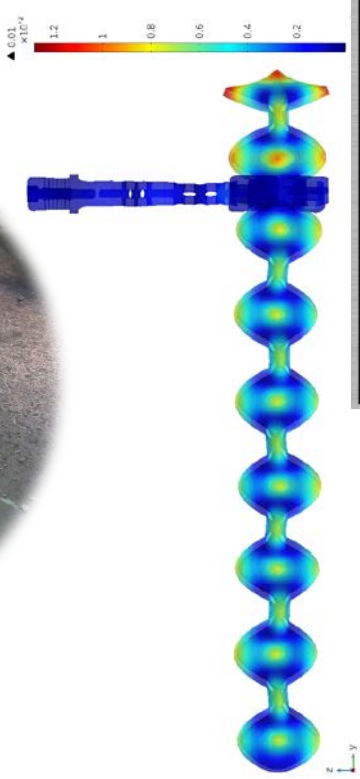
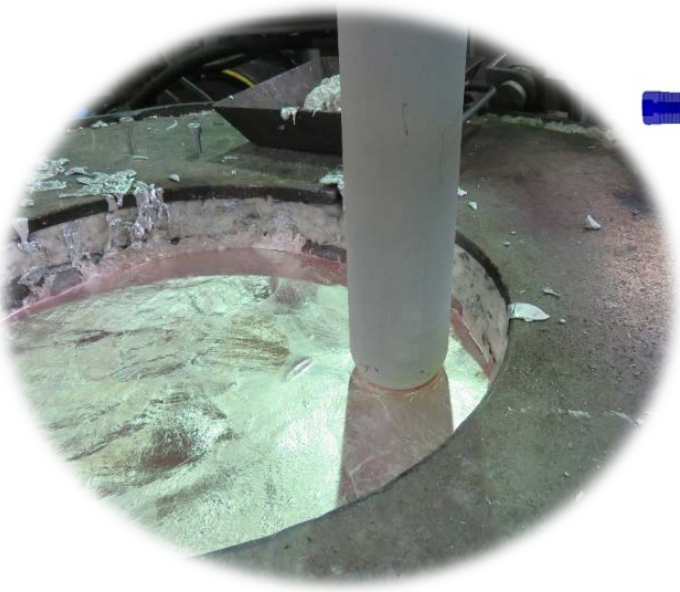
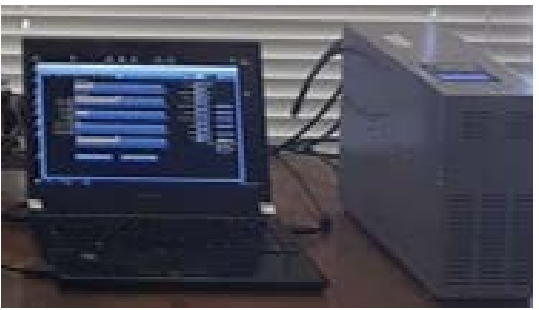

Proposals for your factory:

Cavitation in Metallurgy

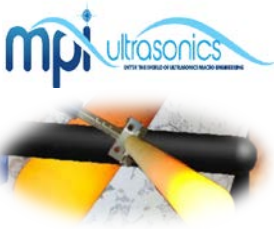

Gravity Casting

Dynamic, almost non-stationary, randomized and time-variable, pulse-repetitive, and phase-frequency modulated ultrasonic waves are producing strongest effects of cavitation and realizing spatially uniform, ultrasonic liquids processing.

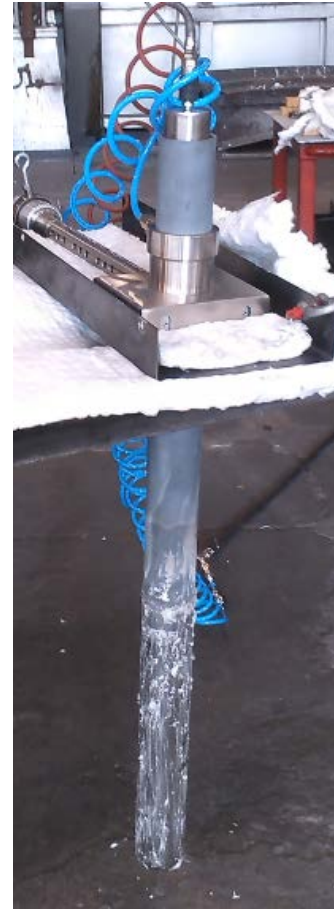
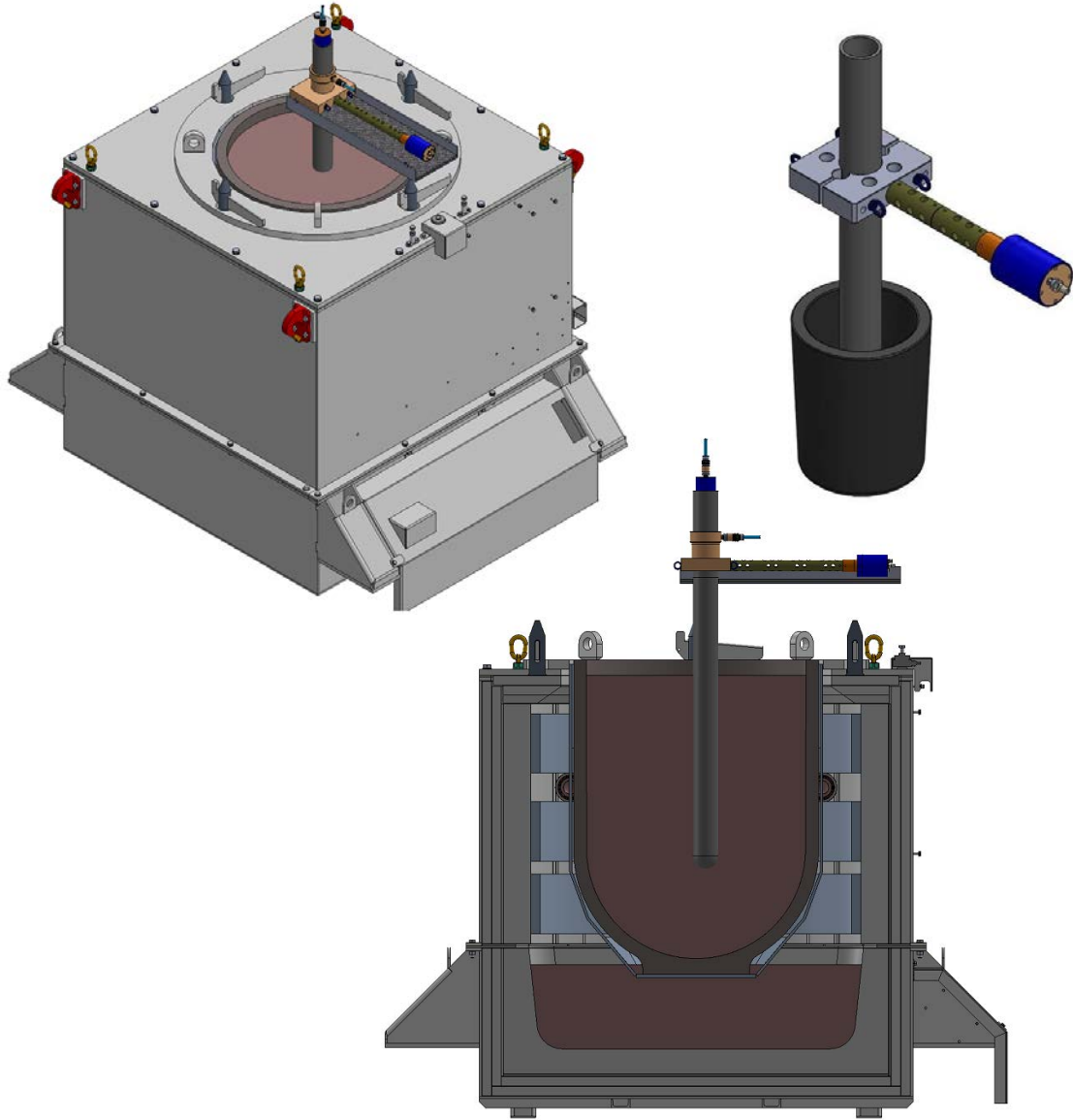

New Device for You

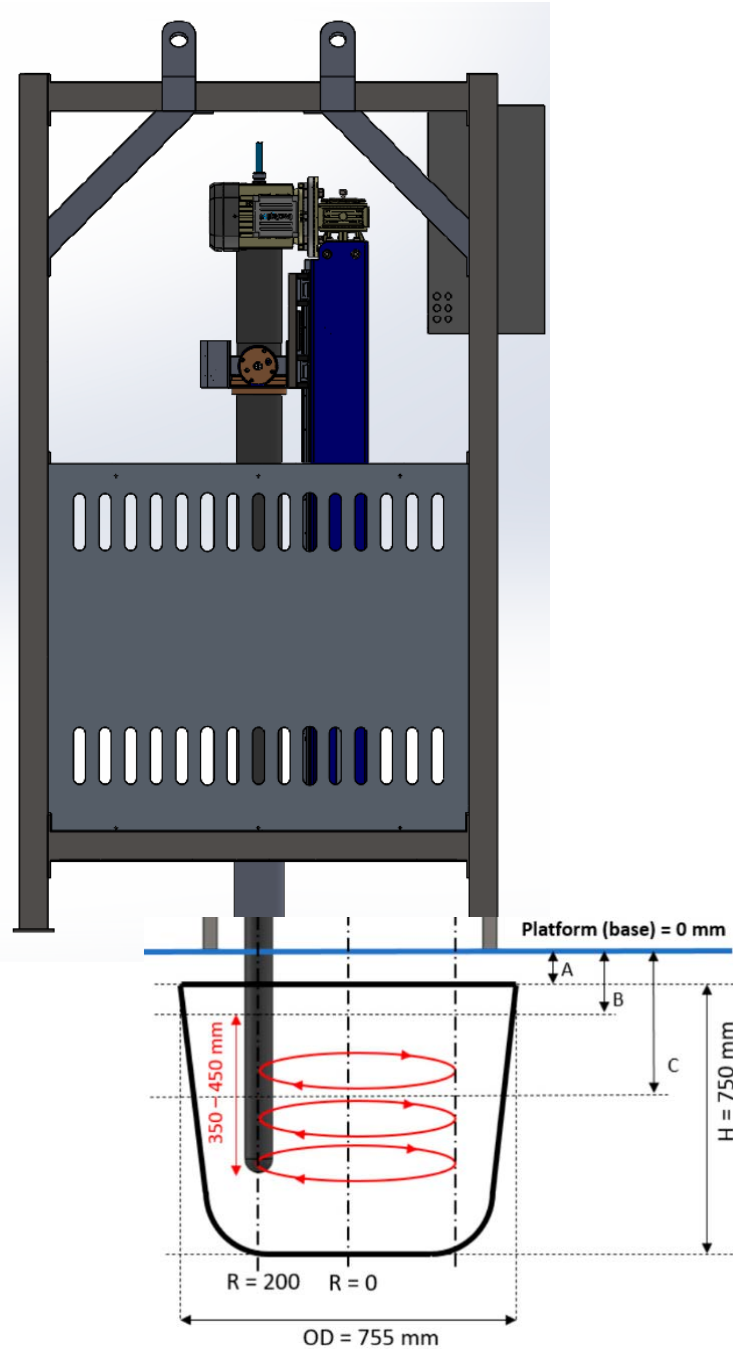
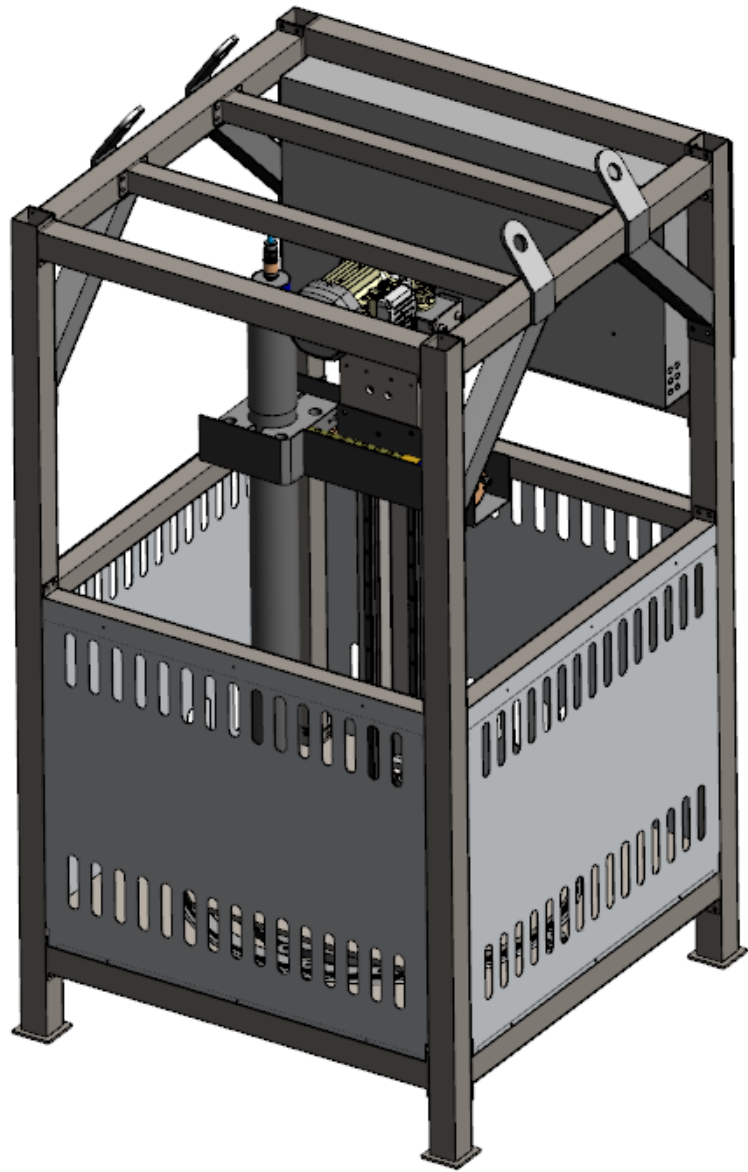
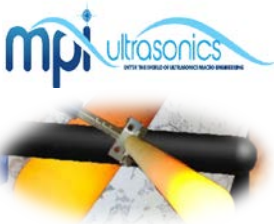

Dynamic Stirring rotation
available for degassing of aluminum
alloys in a
furnace / crucible

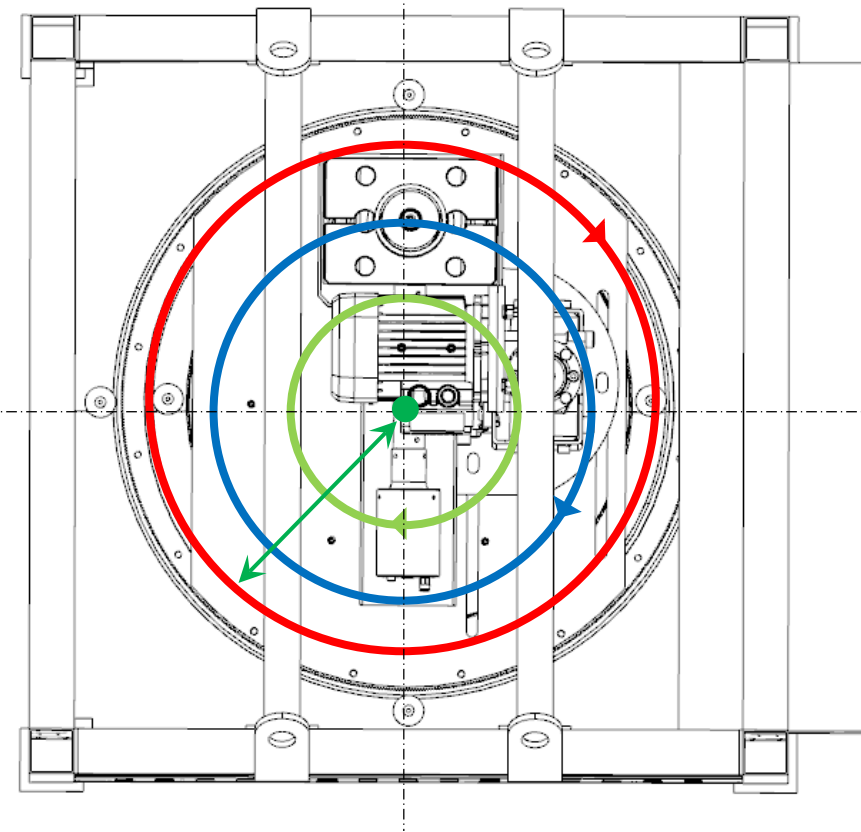

Optical microscope (OM) and Scanning Electron Microscope (SEM) with quantitative metallographic analysis capability are used to evaluate the shape and grain size of constituents .

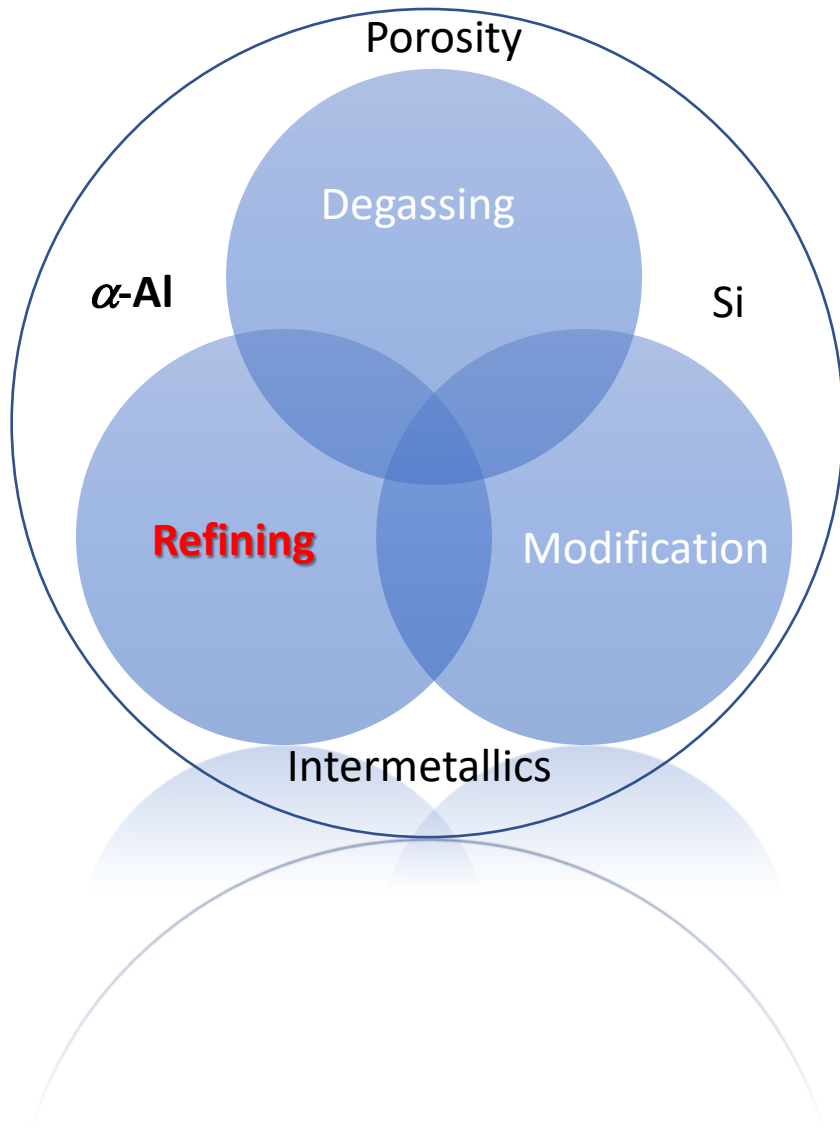

Al-Si-Cu before ultrasonic processing

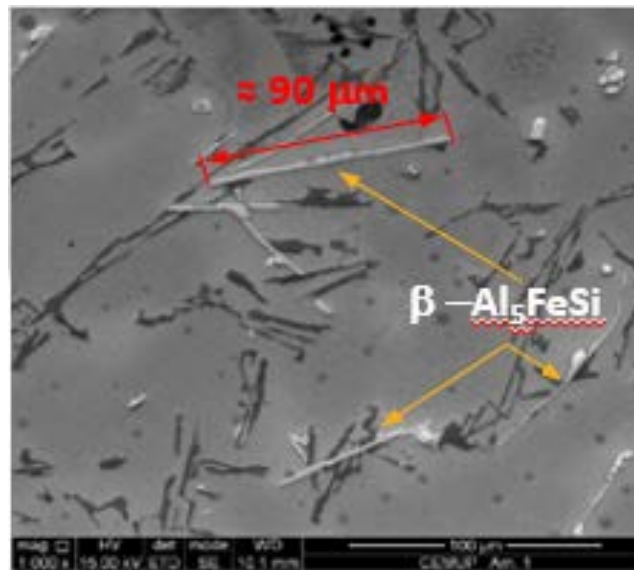
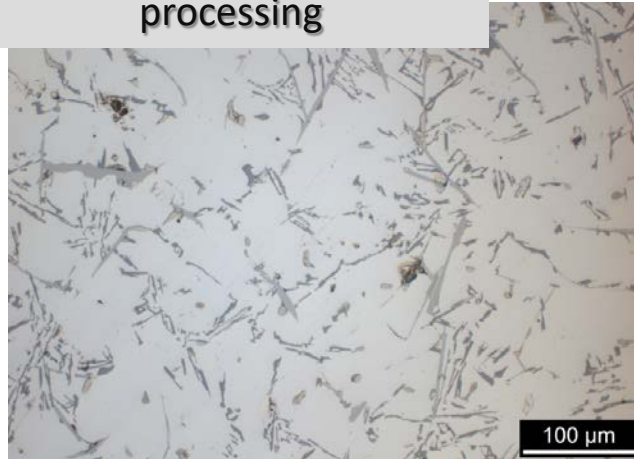

Al-Si-Cu after ultrasonic processing

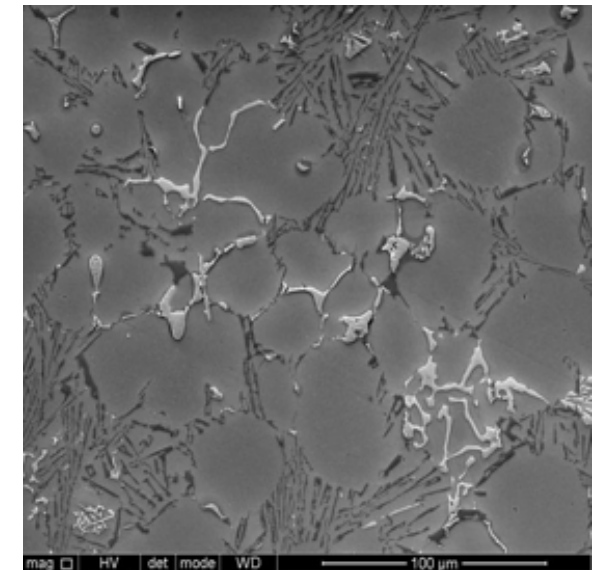
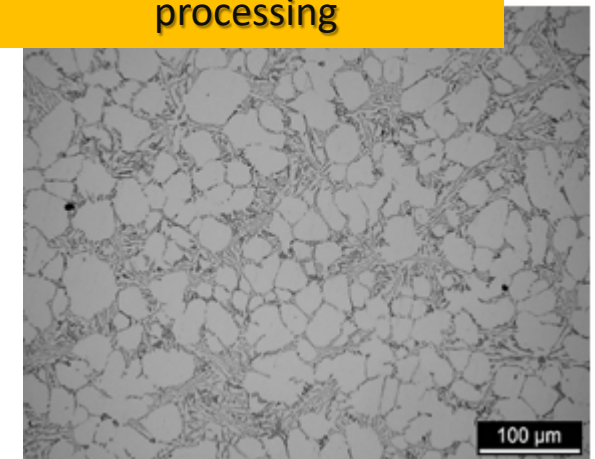

Optical microscope (OM) and Scanning Electron Microscope (SEM) with quantitative metallographic analysis capability are used to evaluate the shape and grain size of constituents.

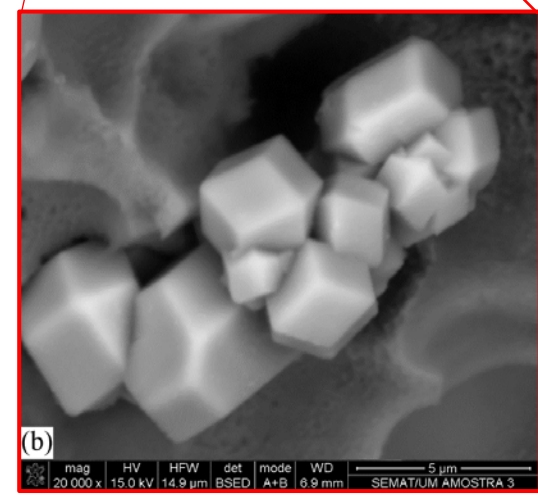
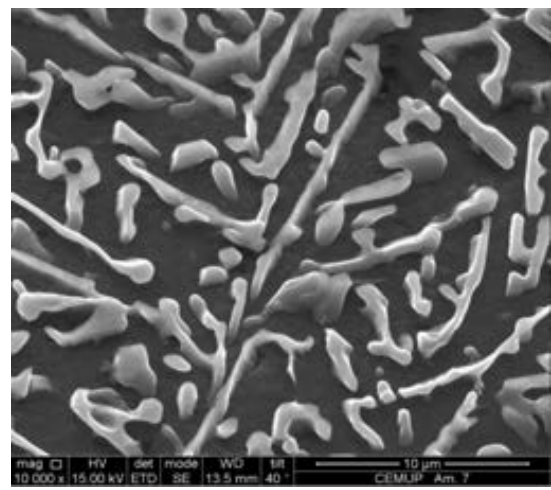
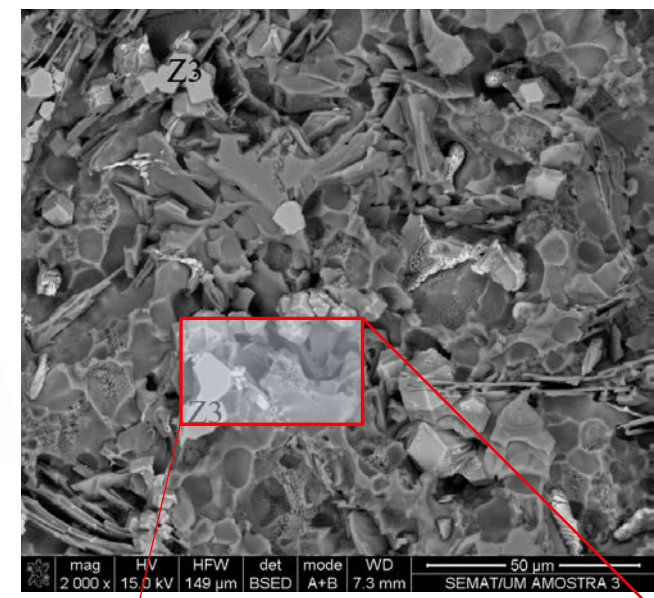
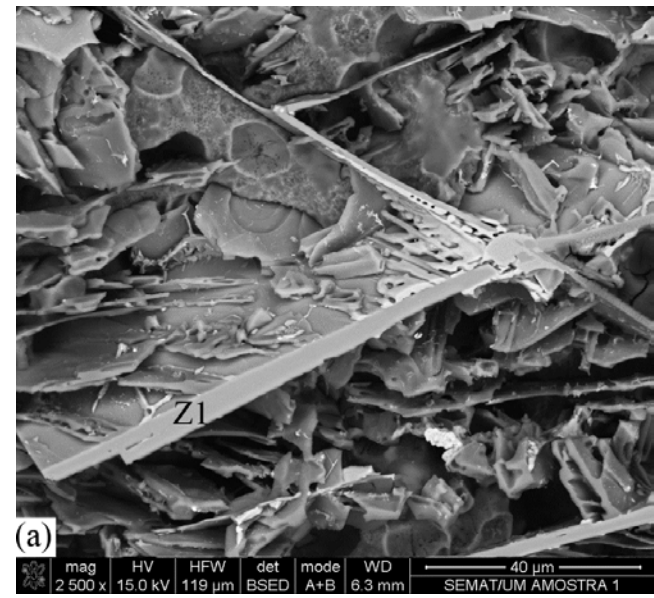
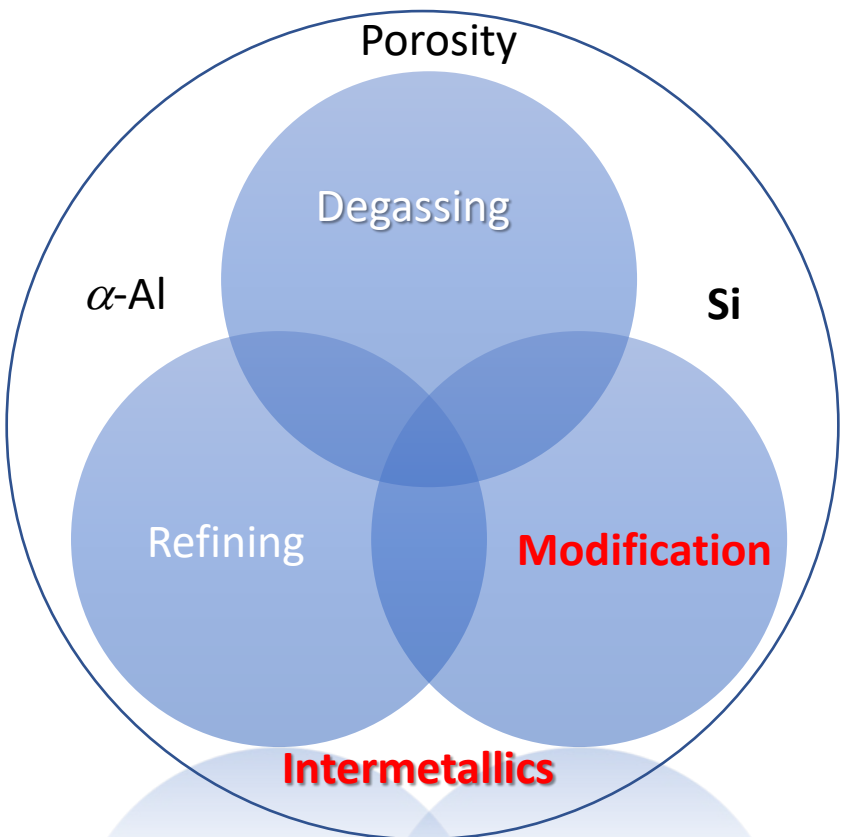

Proposal for your factory:

Cavitation in Metallurgy

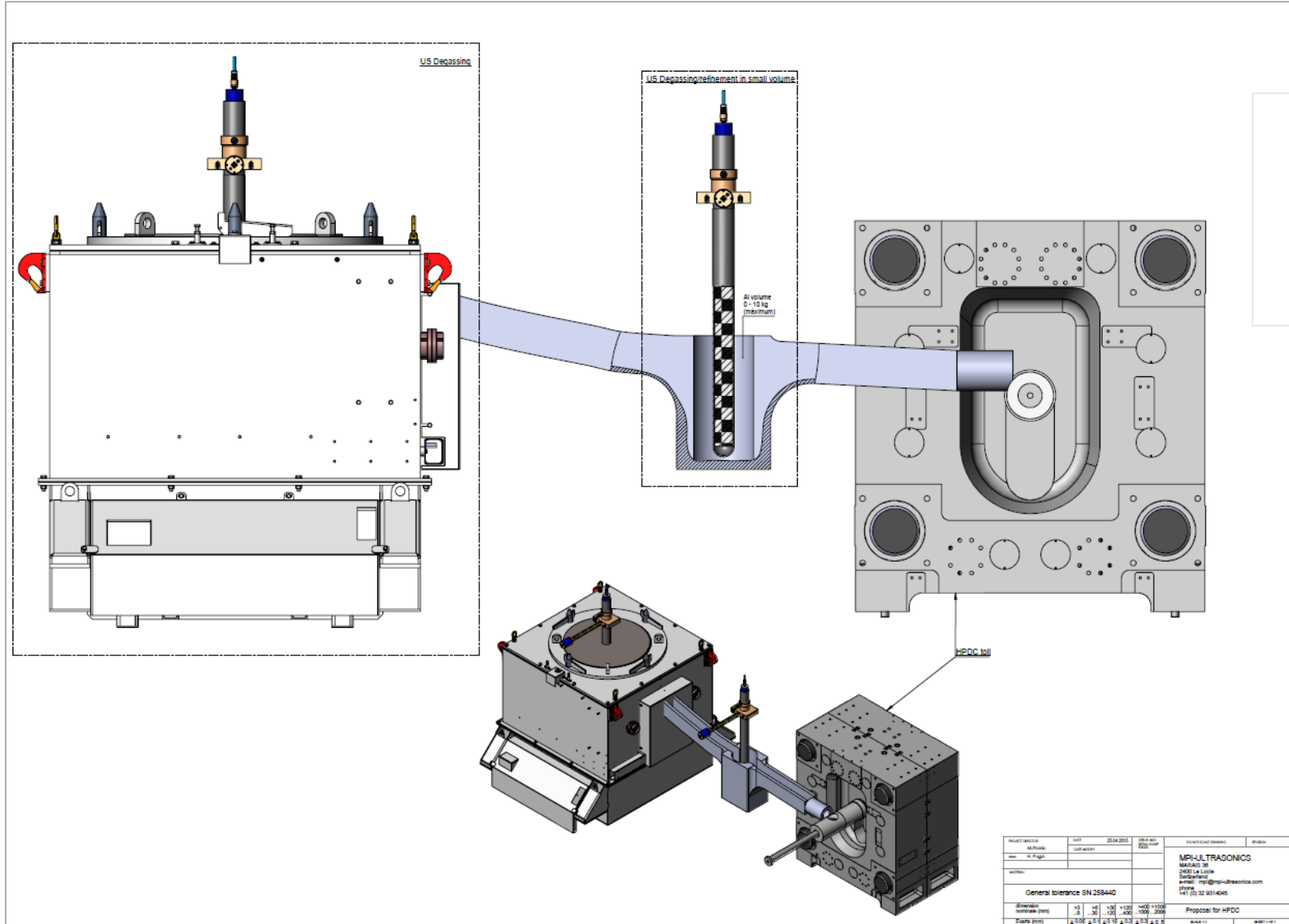

available for degassing and refinement localized of aluminum alloys in a **HPDC process**

PROJECT NUMBER	DATE	26.04.2012	SCALE	1:1
DRAWN	BY	MP	CHECKED	MP
APPROVED	DATE			
General tolerance SN 258440				
Dimension	h6	h7	h8	h9
tolerance (mm)	±0.01	±0.02	±0.03	±0.04
Scale (mm)	1:1	2:1	3:1	4:1
MPI-ULTRASONICS MANAGER OF 2400 Le Locle Switzerland e-mail: mpi@mpi-ultrasonics.com phone: +41 (0) 32 831 4045				
Proposal for HPDC				
MPI-ULTRASONICS				

... proposal for your factory: Cavitation in Metallurgy

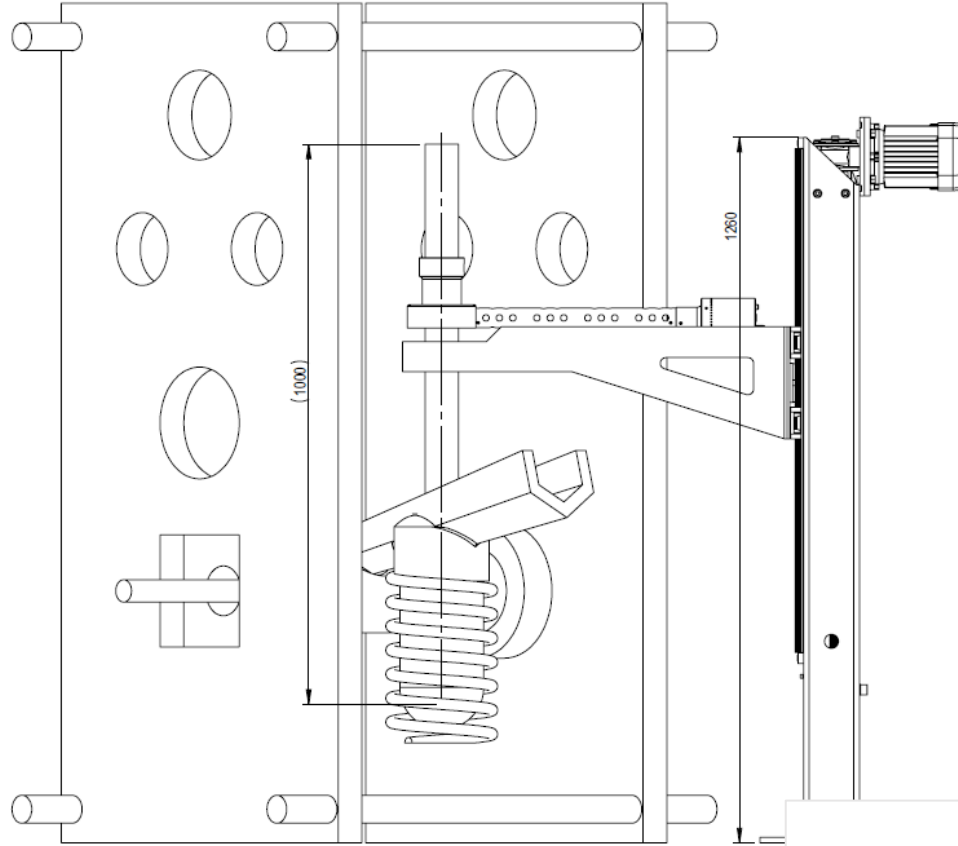
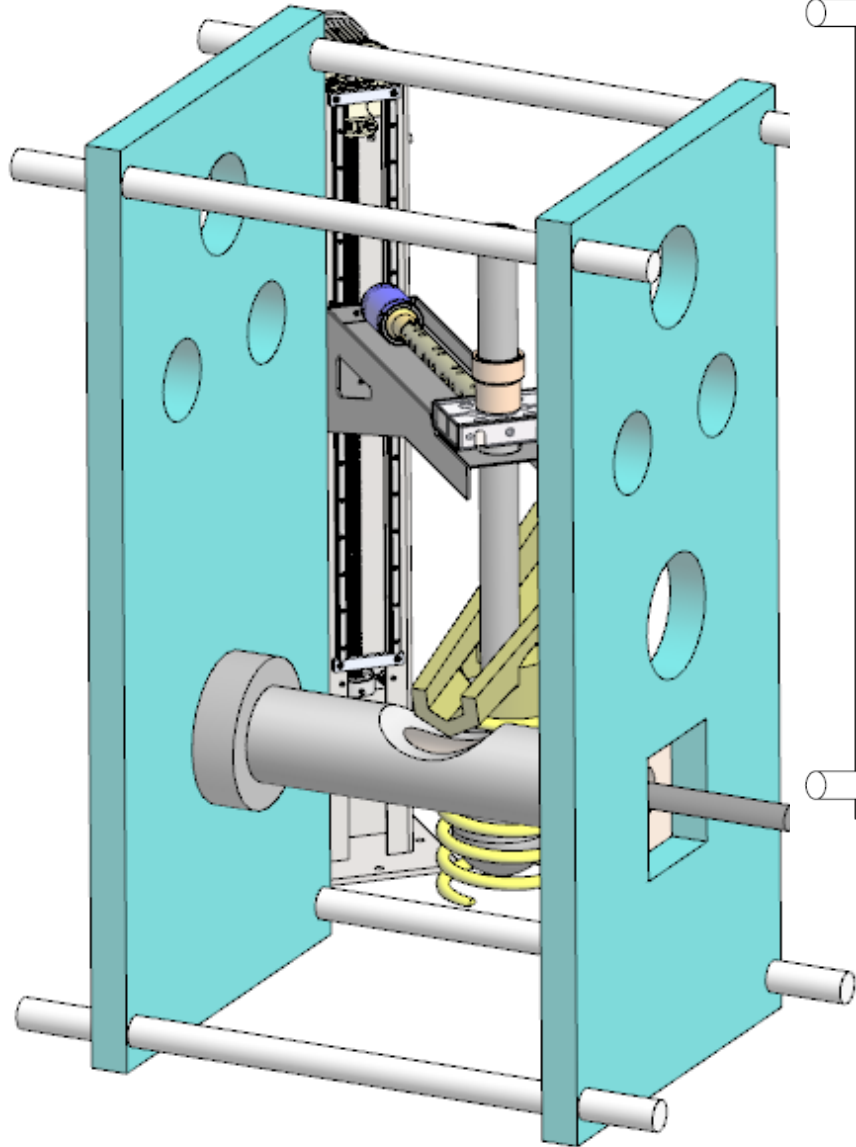

available for degassing and
refinement localized of aluminum
alloys in a
HPDC process
new adjustable concept

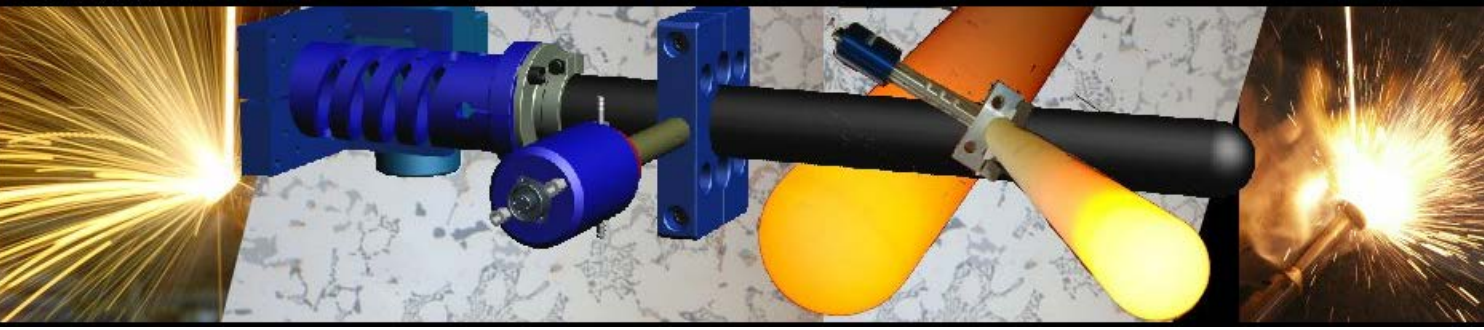

www.UltrasonicMetallurgy.com

The future of your company starts here with MMM
Technology.

Thank You.

MP Interconsulting
Marais 36,
2400 Le Locle, Switzerland
www.UltrasonicsWorldGroup.com

Phone: +41-32-9314045
Fax: +41-32-9314079
www.mpi-ultrasonics.com
mpi@mpi-ultrasonics.com